

TOYOTA *LAND CRUISER*



TOYOTA

TOYOTA MOTOR CORPORATION

FJ/E-8411/©/Printed in Japan/No.77937/18,000

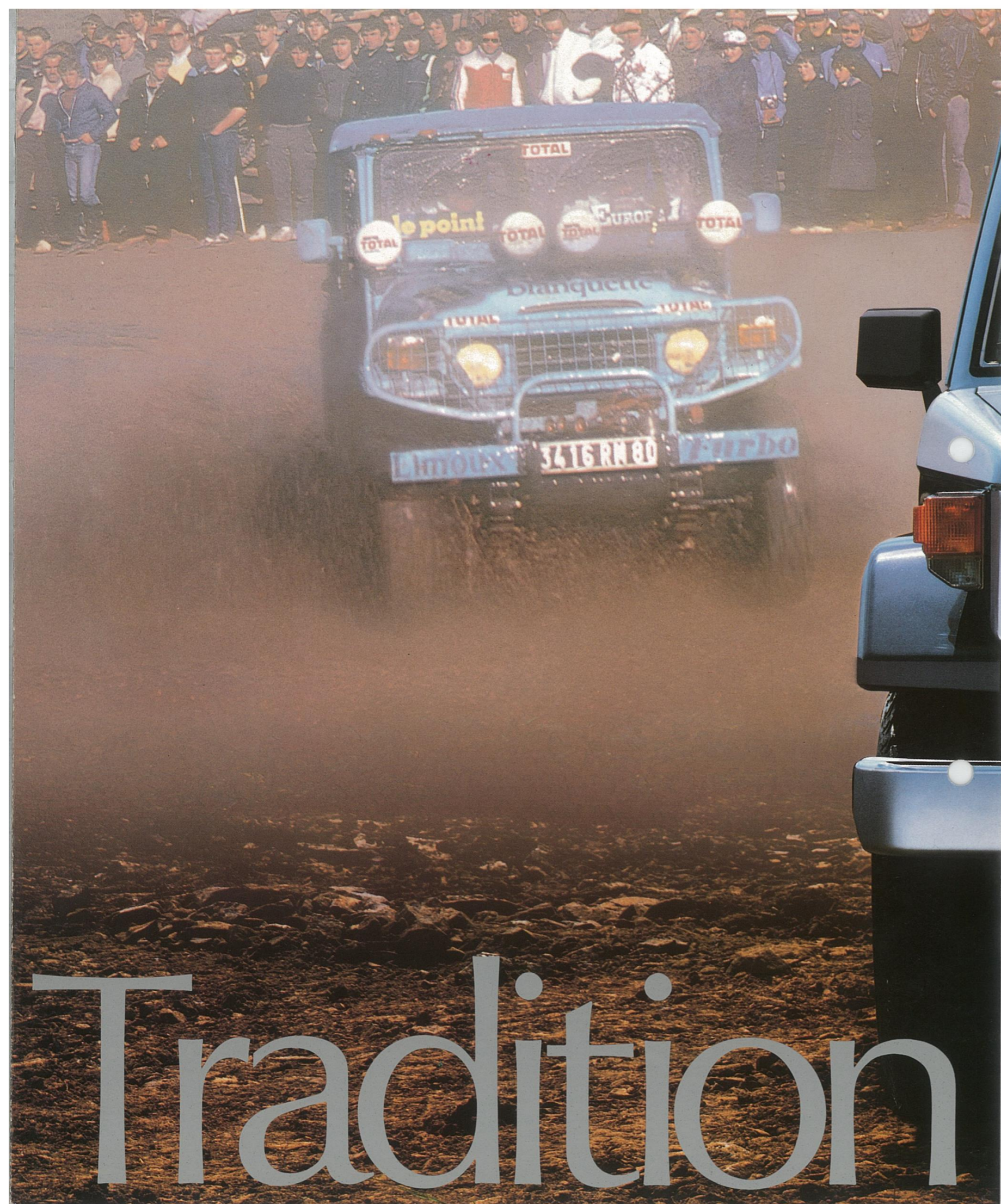

Tradition

Where the road ends, the legend of Land Cruiser begins. All over the world Land Cruiser is a trusted partner.

Hard Top, Short Wheelbase

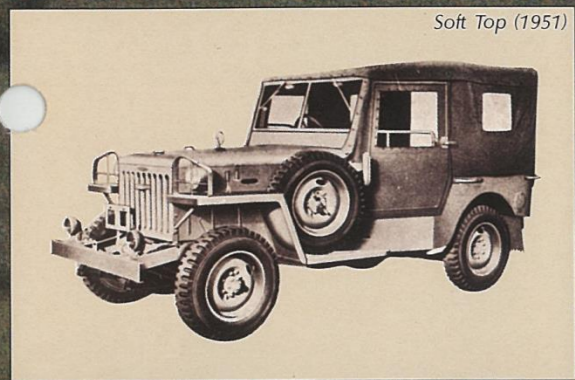
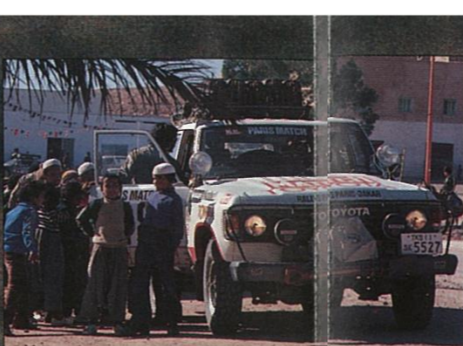

Soft Top (1951)

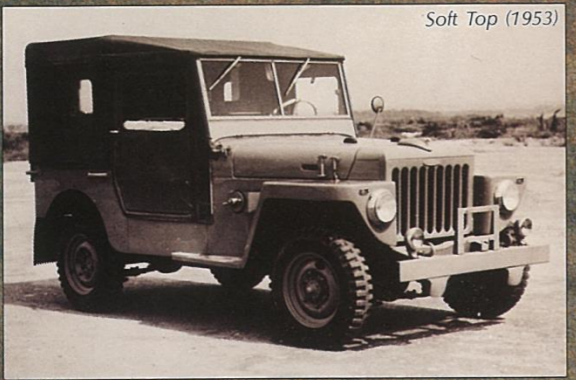

Soft Top (1953)

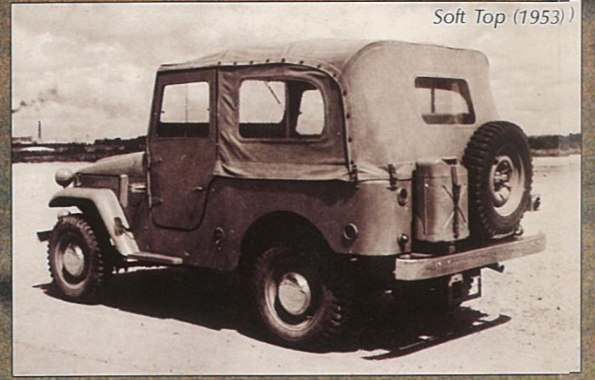

Soft Top (1953)



Soft Top (1955)

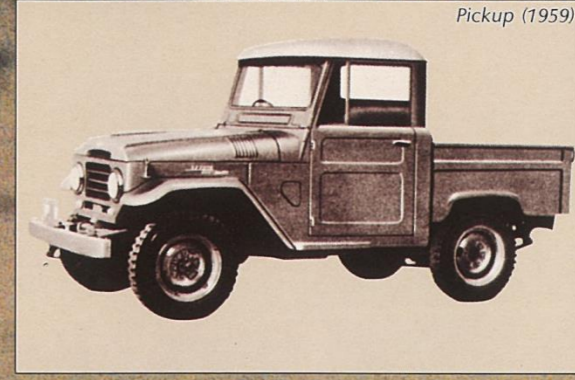

Pickup (1959)



Station Wagon (1967)





Hard Top



Soft Top



Soft Top



Pickup



Hard Top



Station Wagon, Standard Roof

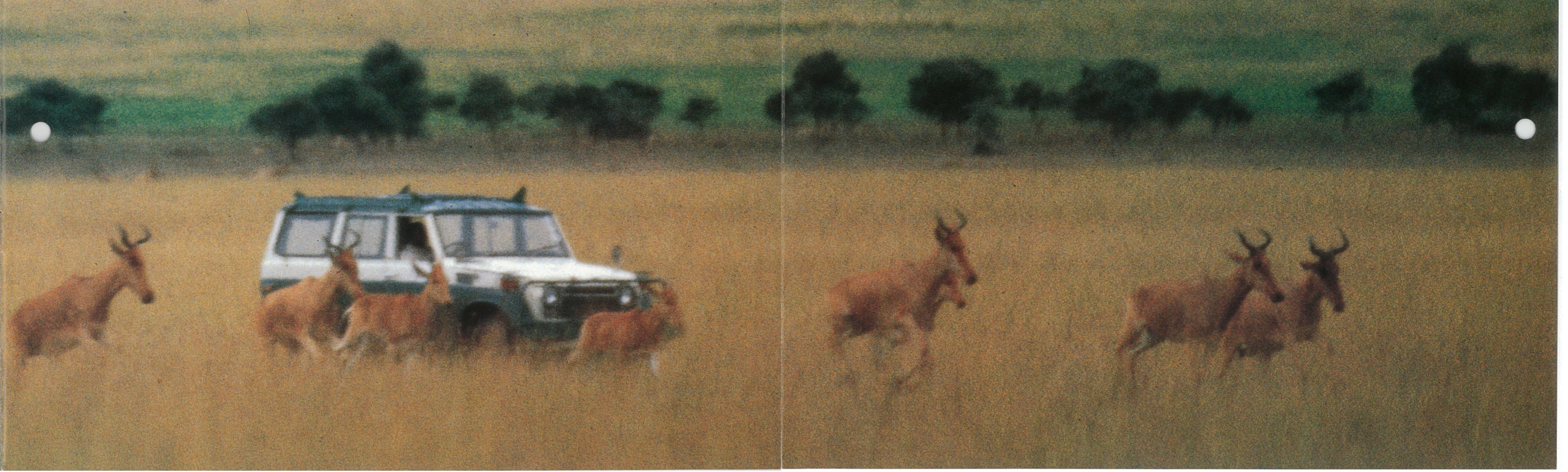



Modern

Now there's a new Land Cruiser, with fresh modern styling that features aerodynamic lines and large areas of flush-fitting curved glass.

FRP Top, Middle Wheelbase



Powerful

Land Cruiser's famous durability is matched with powerful new engines made to perform over rough terrain.

Hard Top, Short Wheelbase

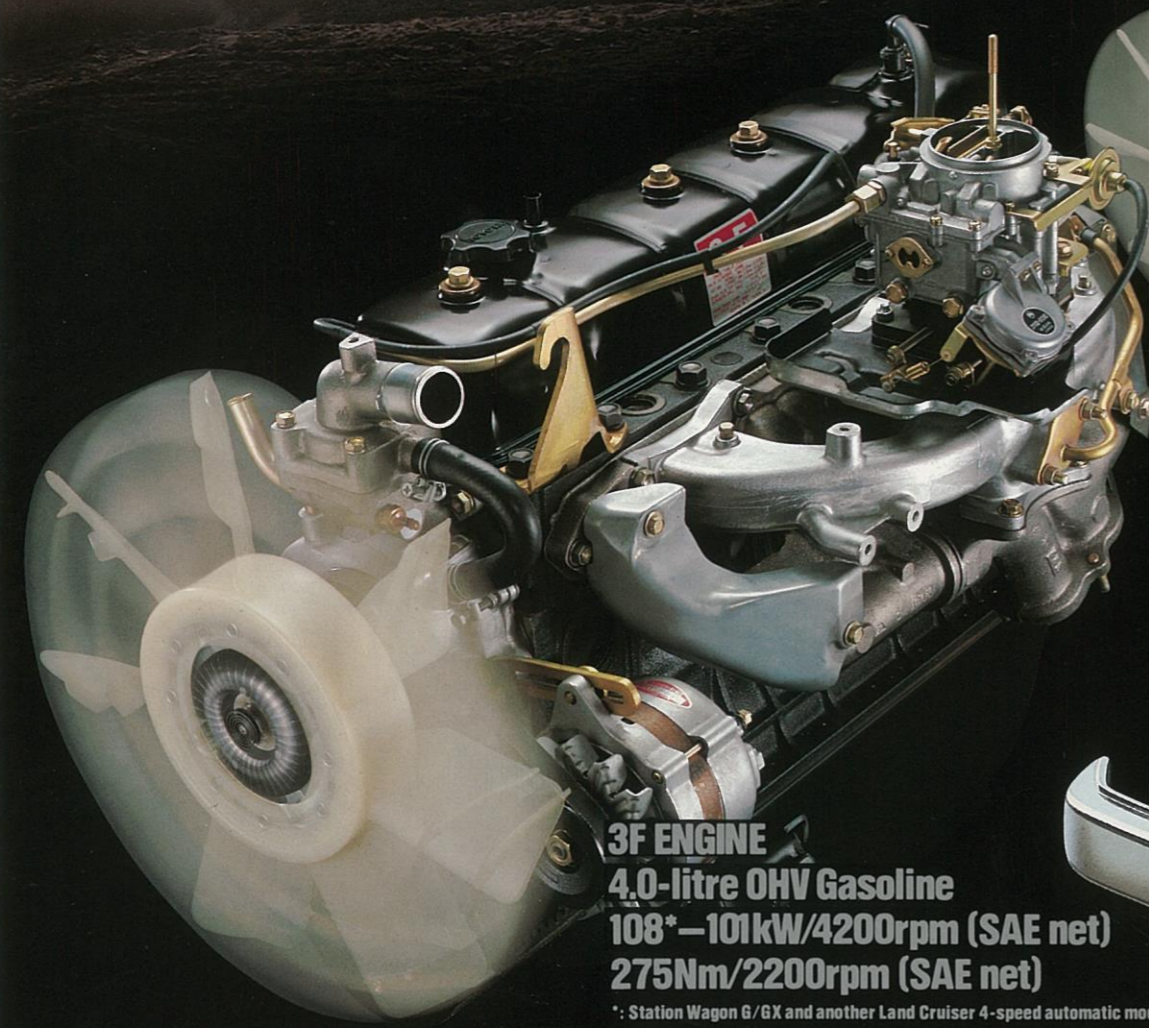

3F ENGINE
4.0-litre OHV Gasoline
108*–101kW/4200rpm (SAE net)
275Nm/2200rpm (SAE net)

*: Station Wagon G/GX and another Land Cruiser 4-speed automatic models.

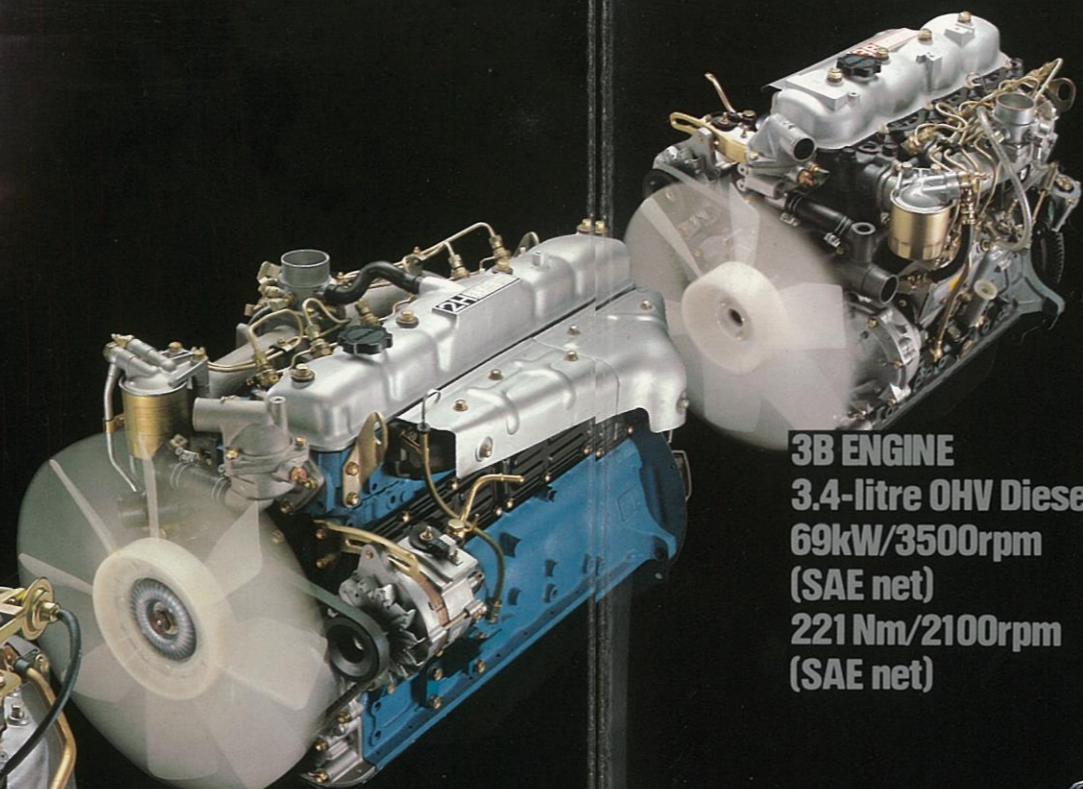

3B ENGINE
3.4-litre OHV Diesel
69kW/3500rpm (SAE net)
221 Nm/2100rpm (SAE net)



2H ENGINE
4.0-litre OHV Diesel
79kW/3500rpm (SAE net)
246Nm/1800rpm (SAE net)



Illustration shown is of European specifications.

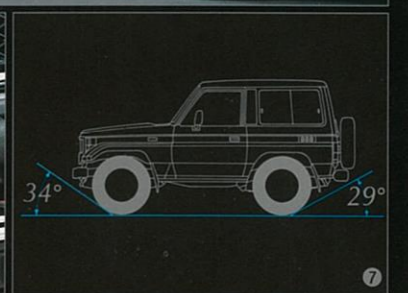
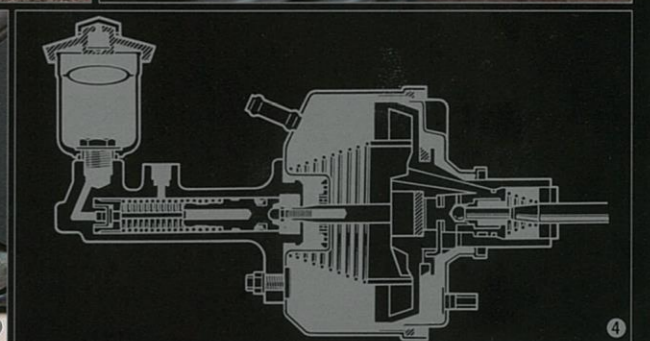

A new, more powerful Land Cruiser.

Land Cruiser's big 4.0-litre gasoline engine is lighter, yet more powerful with better fuel economy. What's more, the 4.0-litre diesel is improved and the faithful 3.4-litre is still available. There's a tough, modern suspension that maintains Land Cruiser's reputation for rugged traction, and adds a new kind of comfort. And there's a new automatic transmission—a Land Cruiser first.

New suspension offers far more comfort, yet retains that Land Cruiser durability. Longer leaf springs in back, and stabilizer bar in front, complete the picture. The large new differential ups four-wheel-drive traction. And free-wheeling hubs make on-road cruising smoother and more efficient.

① New automatic 4-speed transmission gives extra-powerful low gear go. Overdrive top gear for cruising ease. Lock-up clutch cuts hydraulic power loss (available on Short Wheelbase gasoline

models). ② Five-speed manual transmission teams up with easy-use two-/four-wheel-drive transfer gear. ③ One-touch 2-4 selector switch for easy operation. (Standard on models with automatic transmission. Optional on others.) ④ With optional clutch booster, 40% less pressure is needed on the pedal. ⑤ Optional stylish overfender with 10R-15 radial tyre. ⑥ Powerful electric winch is optional. ⑦ Short Wheelbase Land Cruisers have a steep approach angle for rough terrain.

LAND CRUISER

FRP TOP

Comfort

This new Land Cruiser will surprise you with its comfort. You'll find new seats and new conveniences.

FRP Top, Middle Wheelbase



Short Wheelbase



Soft Top/Hard Top

The heavy-duty rough-terrain vehicles. Short Wheelbase Land Cruisers. Short Wheelbase Land Cruisers are the tough vehicles that take you to rough terrain. And now these rugged Land Cruisers, both Hard Top and Soft Top, have a fresh modern look. You'll notice the new styling immediately—a tough, masculine profile that updates the great Land Cruiser tradition. There's a new crisp front fender line and clean contemporary styling—an aerodynamic profile that employs curved glass, fit flush with the body panels to reduce drag for better high-speed cruising and economy. You'll also find 40% more glass area for better visibility.

Body type	Engine	Wheelbase	Seating capacity
Hard Top	4.0-litre gasoline	Short	2, 3, 5, 6, 7
Soft Top	3.4-litre diesel		

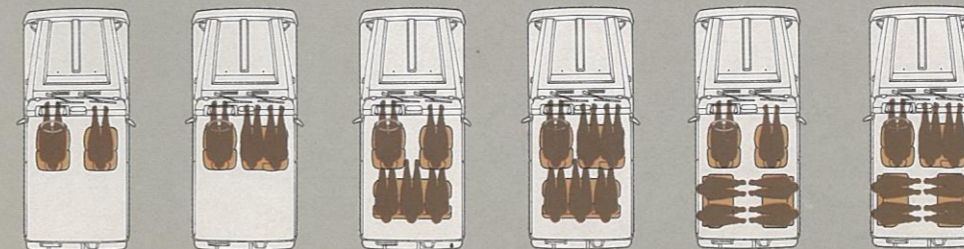

Optional electric sunroof opens and closes with a single switch. Its fail-safe system takes the roof to the latch point when CLOSE is pushed, then stops. The switch must be pushed again to close the roof completely.

Middle Wheelbase



FRP Top

Get away from it all with modern styling and more space.

Middle Wheelbase Land Cruisers.

Here's a truly versatile Land Cruiser, with a new modern-looking top made of durable Fibre Reinforced Plastic (FRP). With its bright, contemporary good looks, Land Cruiser FRP Top sets a new standard for off-road vehicle styling. No matter what your leisure plans, the new Middle Wheelbase Land Cruisers are ready to take you there. The longer wheelbase and higher canopy top provide plenty of room inside for passengers to stretch out, and room left over in the rear for cargo. Comfortable and spacious, these Land Cruisers make a great way to get away.

Body type	Engine	Wheelbase	Seating capacity
FRP Top	4.0-litre gasoline	Middle	2, 3, 5, 6
Soft Top			2, 3, 5, 6, 8, 9

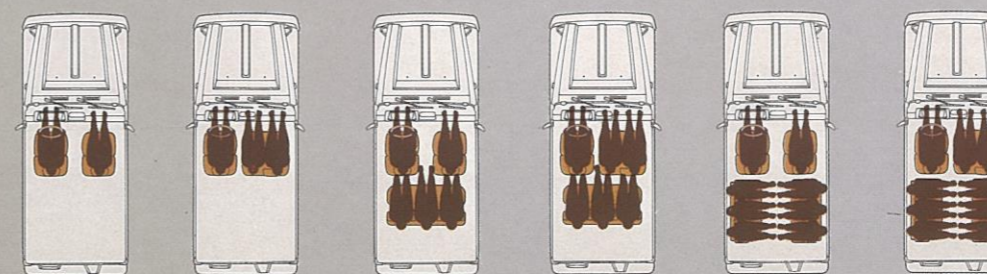

The FRP Top model looks as fresh and stylish inside as it does outside. The interior roll bar is designed to allow greater head room, and complements the stylish roof garnish. It's another example of Toyota's attention to detail and quality.

Long Wheelbase



Hard Top/Pickup

Hard-working vehicles you can trust. Long Wheelbase Land Cruisers. For getting people or a payload to a remote site, nothing beats these big Land Cruisers—the Long Wheelbase Hard Top and Pickup. And like all Land Cruisers, they're built for working under the most adverse conditions. The new Pickup has clean new cab styling, and is now available with sporty side stripes. There's a large deck area, and improved heavy-duty leaf springs to carry big loads. The newly-styled Hard Top is remarkably spacious inside, with a higher roofline, wide cabin and plenty of space to carry lots of passengers in greater comfort than ever before.

Body type	Engine	Wheelbase	Seating capacity
Hard Top	4.0-litre gasoline 4.0-litre diesel	Long	2, 3, 5, 6, 12, 13
Pickup	3.4-litre diesel		3, 12, 13

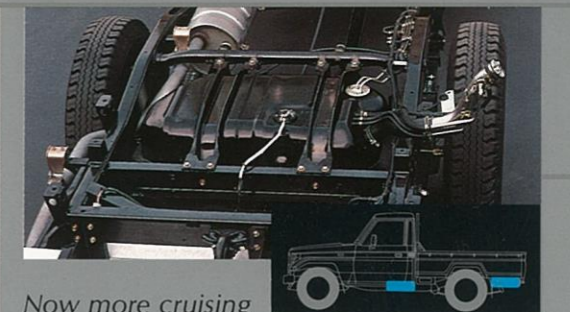
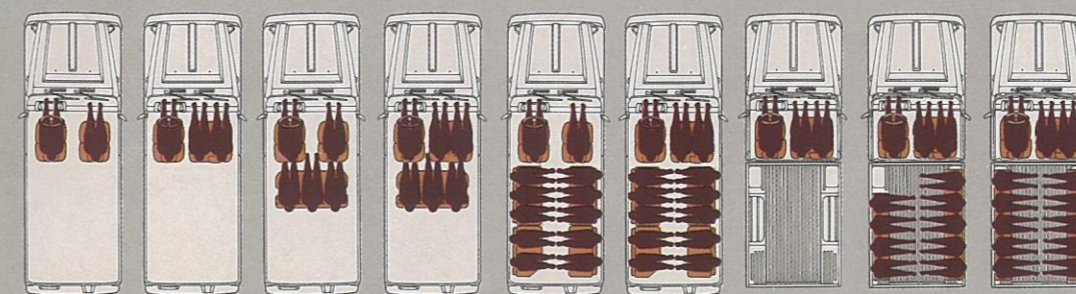

Now more cruising range is yours. With the optional 90-litre extra fuel tank available for Pickups and Hard Tops. That's 180 litres in all, with separate fuel gauges in the dash to tell you at a glance how much running time is left.

LAND CRUISER II



More economy & comfort

A sporty new Land Cruiser II that stands out around town or on a weekend adventure.

Disc wheels and tyres shown are of European specifications.
Hard Top, Short Wheelbase

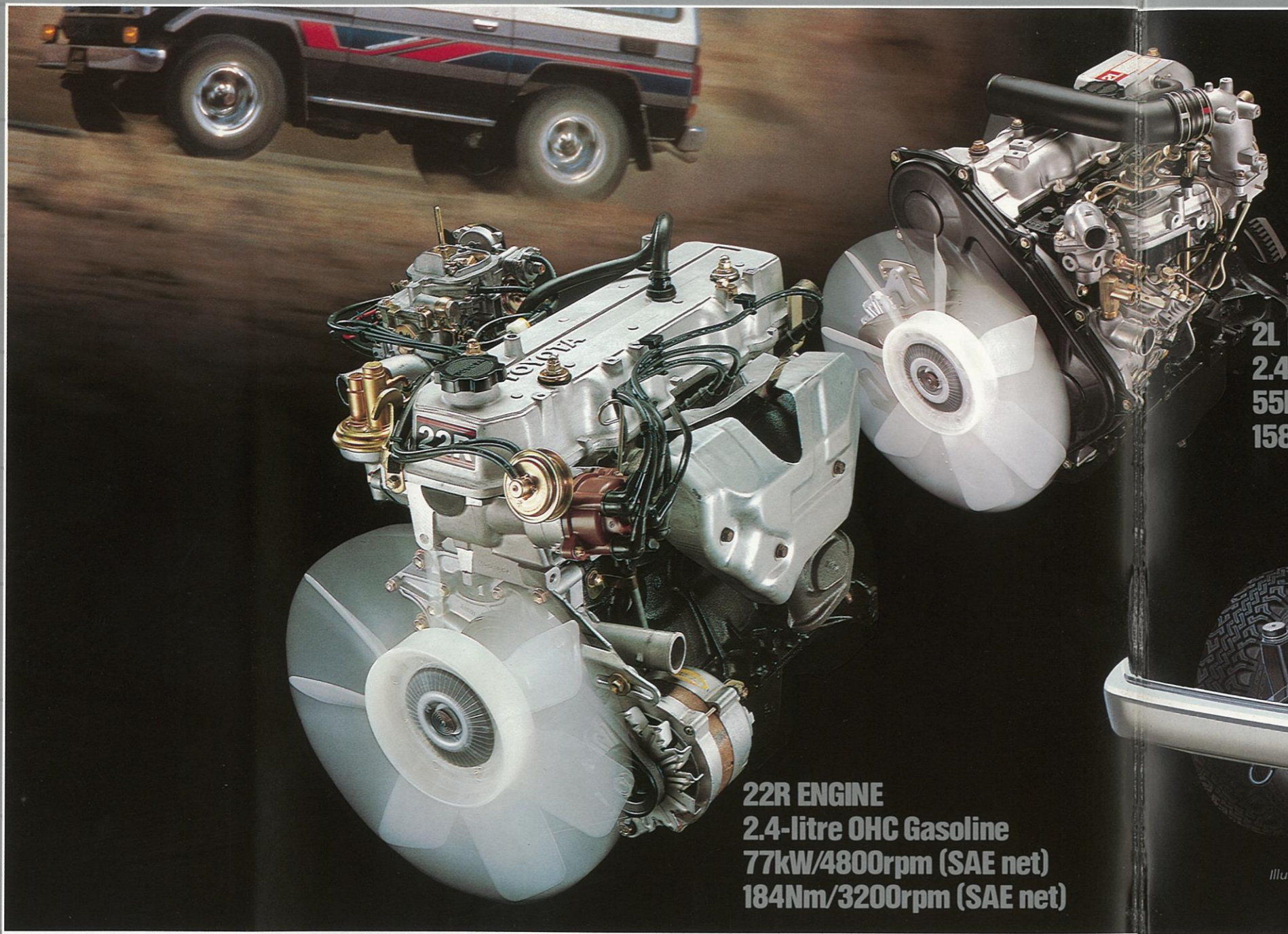

22R ENGINE
2.4-litre OHC Gasoline
77kW/4800rpm (SAE net)
184Nm/3200rpm (SAE net)

2L ENGINE
2.4-litre OHC Diesel
55kW/4000rpm (SAE net)
158Nm/2200rpm (SAE net)

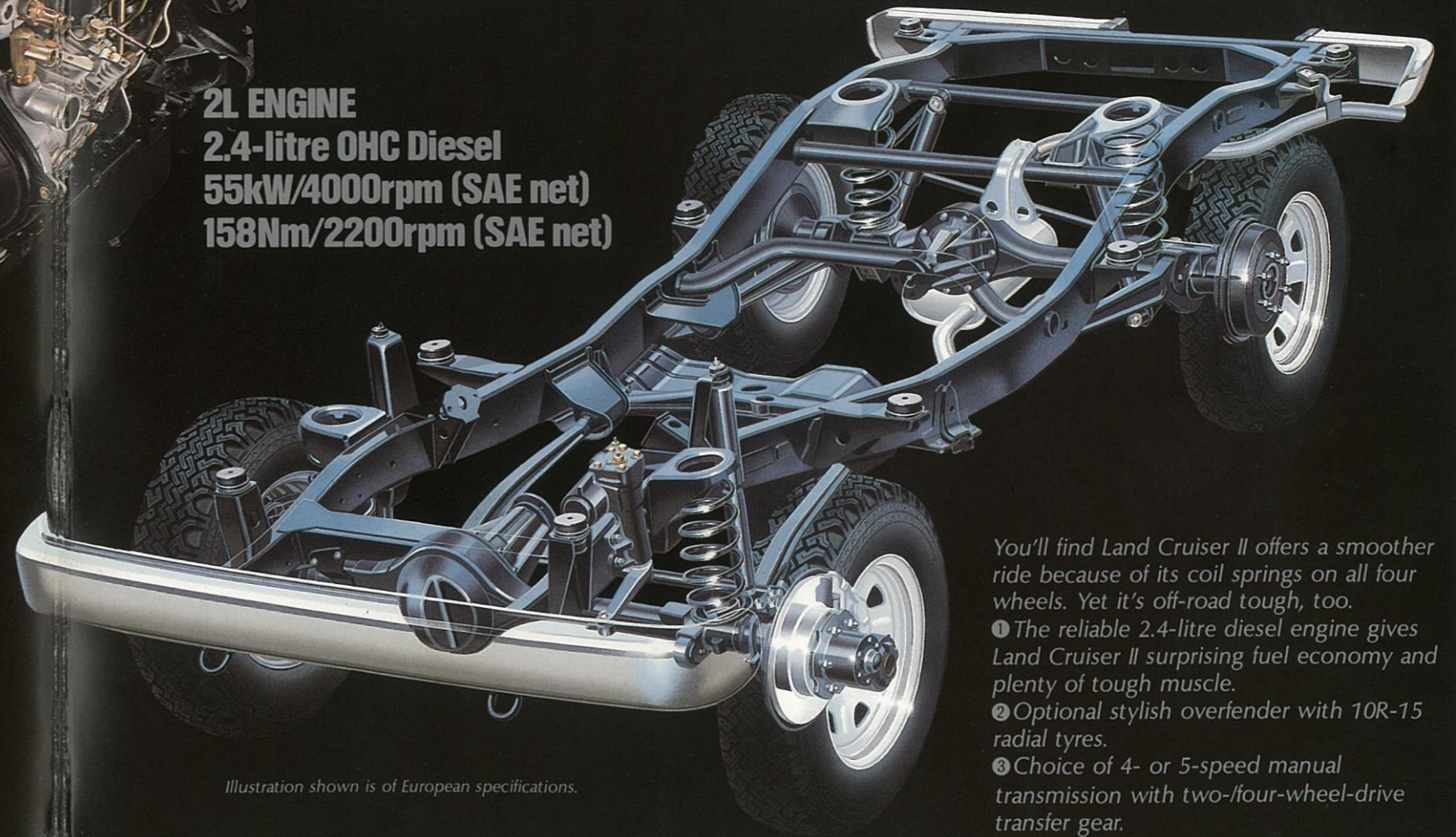
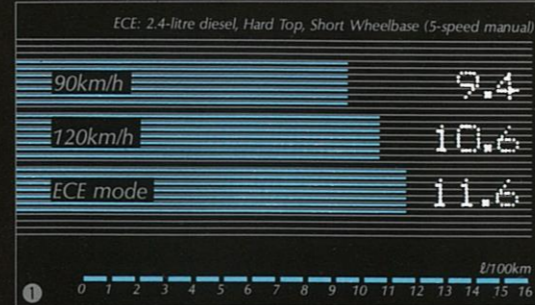

Illustration shown is of European specifications.

You'll find Land Cruiser II offers a smoother ride because of its coil springs on all four wheels. Yet it's off-road tough, too.

① The reliable 2.4-litre diesel engine gives Land Cruiser II surprising fuel economy and plenty of tough muscle.

② Optional stylish overfender with 10R-15 radial tyres.

③ Choice of 4- or 5-speed manual transmission with two-/four-wheel-drive transfer gear.

Nimble and powerful new Land Cruiser II.

New Land Cruiser II is a rugged, fun-loving outdoor vehicle with surprising comfort and outstanding versatility. It's powered by your choice of a strong 2.4-litre gasoline engine or reliable 2.4-litre diesel. Both are designed for light weight and top fuel efficiency. But even though they're lighter, these are true Land Cruiser engines—durable and hard working. Land Cruiser II has coil springs on all four wheels for an extra-smooth ride and, of course, Land Cruiser's famous four-wheel drive transmission.

Body type	Engine	Wheelbase	Seating capacity
Hard Top	2.4-litre gasoline	Short	2, 3, 5, 6, 7
Soft Top	2.4-litre diesel		

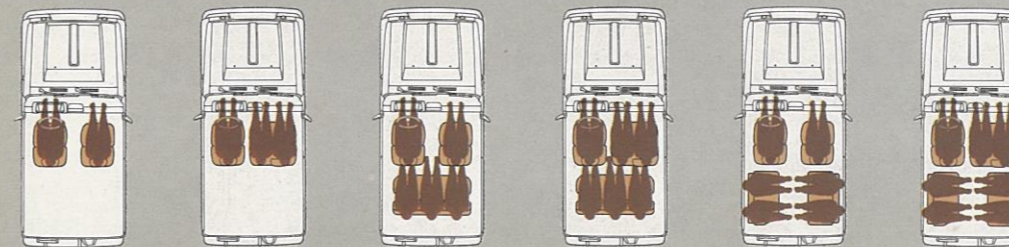

New Land Cruiser II's soft top can be completely removed so you can enjoy the out-of-doors more fully. Built-in roll bar stiffens the top, too. This convertible aspect adds to the sporty air of this new model.

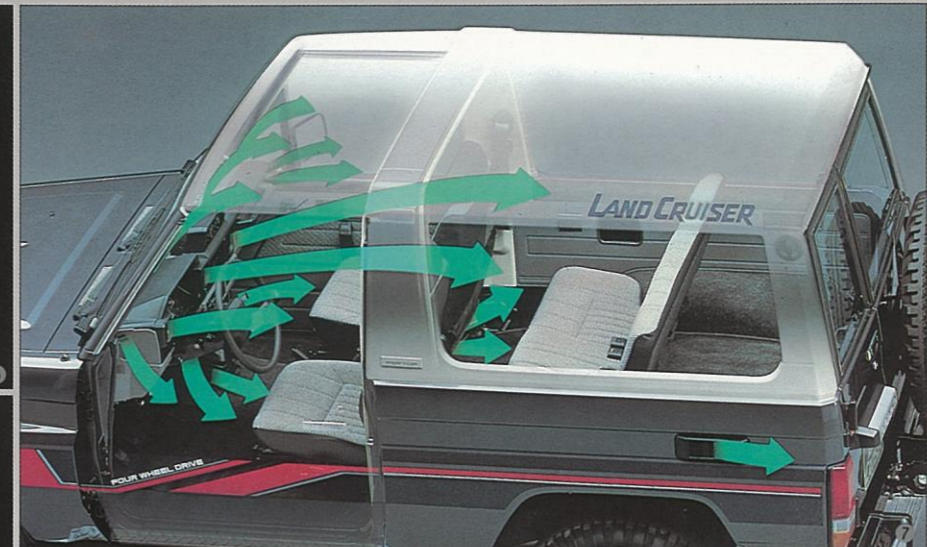
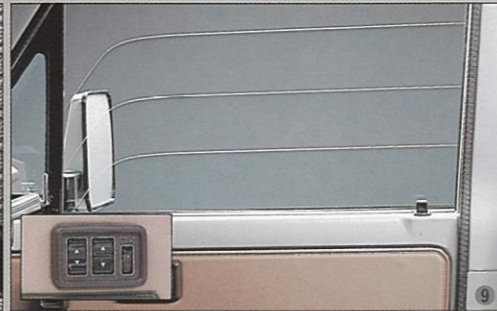
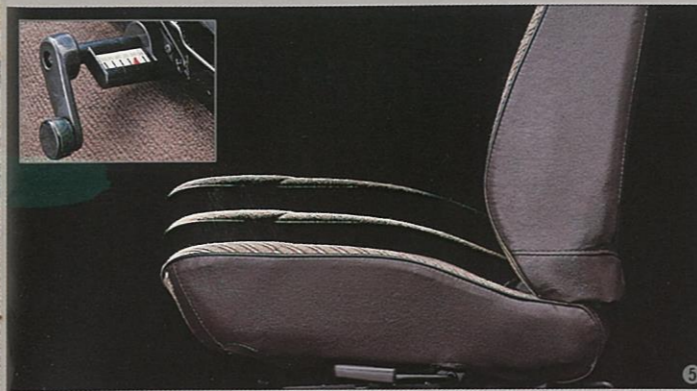
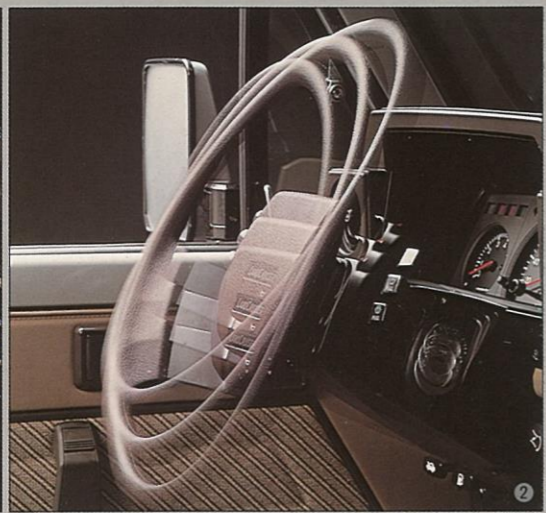

Land Cruiser's surprising new interior comforts.

Land Cruiser is famous for off-road ruggedness. Now, Toyota has made it as comfortable as a passenger car inside. You'll find a crisp modern dash panel, big bright interior, and well-upholstered comfortable seats. In addition to thorough ventilation and great visibility, you'll find such unexpected optional luxuries as tilt steering, power windows and fine car stereo.

① Optional power steering adds driveability to Land Cruiser ruggedness. ② Optional tilt steering lets the driver set the wheel at the most comfortable angle. ③ Optional AM/FM radio and hi-fi stereo. ④ Optional accessory meter console can contain an altimeter and clinometer, or a fuel gauge for the optional 90-litre tank. ⑤ Optional two-stage suspension seat smooths out Land Cruiser's on- and off-road ride. ⑥ Optional front bench seat swings forward for easy access

to the rear. (Seat shown is of European specifications.) ⑦ Land Cruiser ventilation is designed for optimum operation. (A: Front ventilation control is set in dash panel for easy operation. B: Rear heater control is optional for Short and Middle Wheelbase models. C: Rear heater control is optional for Hard Top, Long Wheelbase models.) ⑧ Optional console box. ⑨ Power windows are an option on Hard Top, Short Wheelbase and FRP Top models.

⑩ Optional rear wiper/washer and defogger helps keep the view to the rear clear in all kinds of weather (Hard Top, Short Wheelbase and FRP Top models). ⑪ Optional fog lamps provide added visibility. ⑫ Optional roof-top rack. (Hard Top, Short/Long wheelbase models) ⑬ Large side step facilitates access. ⑭ The rear step bumper (optional for Pickup models).

Available options differ with grades and body types. Get details from your Toyota dealer.

Station Wagon



Luxury

Land Cruiser Station Wagon puts you in a luxurious setting for enjoying any kind of outdoor leisure activity.

Wagon G, Standard Roof

Station Wagon



Wagon G, High Roof/Wagon, Standard Roof

Handsome styling and greater comforts—luxurious Land Cruiser Station Wagon. Outdoor life will never be the same. Luxurious Land Cruiser Station Wagon brings high style and luxurious comfort to the toughness and dependability of Land Cruiser. Crisp aerodynamic styling improves high-speed stability and provides a new level of car-like comfort inside. Land Cruiser Station Wagon is available in Standard and High Roof variations in “Wagon G” and “Wagon” models and High Roof “Wagon GX” with a third seat. Land Cruiser Station Wagon has plenty of power, handles easily, and lives up to the Land Cruiser tradition of tough off-road performance and durability.

Grade	Body type	Engine	Seating capacity
Wagon	Standard Roof	4.0-litre gasoline/diesel 3.4-litre diesel	5, 6, 9, 10
	High Roof	4.0-litre gasoline	5, 6, 8, 9, 10
Wagon G	Standard/High Roof	4.0-litre gasoline	5, 6
Wagon GX	High Roof	4.0-litre diesel	8, 9

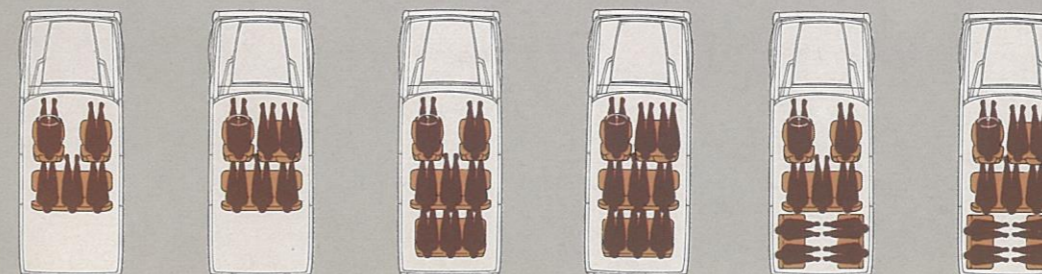

Land Cruiser Wagons now have front/rear air conditioning available. Controls are separate so the rear cooling can be set from either front or rear seats. Ducts are led to the ceiling between the second and third seats so that occupants of both get adequate cool air.



Wagon G, High Roof



① Land Cruiser seats adjust on a long positioning track, and they recline fully for individualized comfort. ② Headrests for the second seats are optional. ③ Optional power windows add a touch of comfort. ④ Rear heaters are available as comfortable

options. ⑤ Optional fuel lid can be opened from the driver's seat. ⑥ Wagon G back door swings up for easy access. ⑦ Wagon rear swing-out doors.

Available options differ with grades and body types. Get details from your Toyota dealer.

Inside the Station Wagon—exceptional comforts.

Hard to believe you're sitting in a rugged four-wheel-drive vehicle. Land Cruiser Station Wagon looks more like a well-appointed luxury car. Settle back in finely-upholstered soft seats that are moulded for excellent lateral support. Front seats recline to an almost flat position, and have adjustable head rests. The interior is fully carpeted, and finished in high quality trim. A handy console box between the front seats provides a convenient storage place for your small items. Turn on the air conditioner, relax with a little stereo music. This is a truly unique Land Cruiser experience.

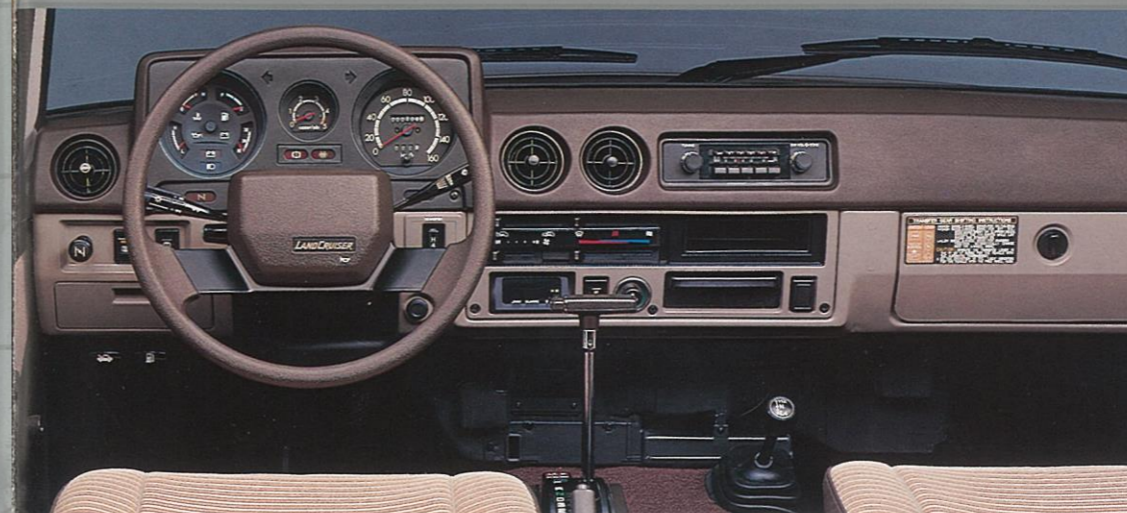

Land Cruiser Wagon's instrument panel has been modernized and made more useful. Every control, every switch, and every meter is placed ergonomically for convenience, letting you monitor the condition of the vehicle at all times. An automatic transmission allows virtually anyone to enjoy off-road driving. And four-wheel drive can be selected with one-touch 2-4 selector switch.

Wagon G, High Roof

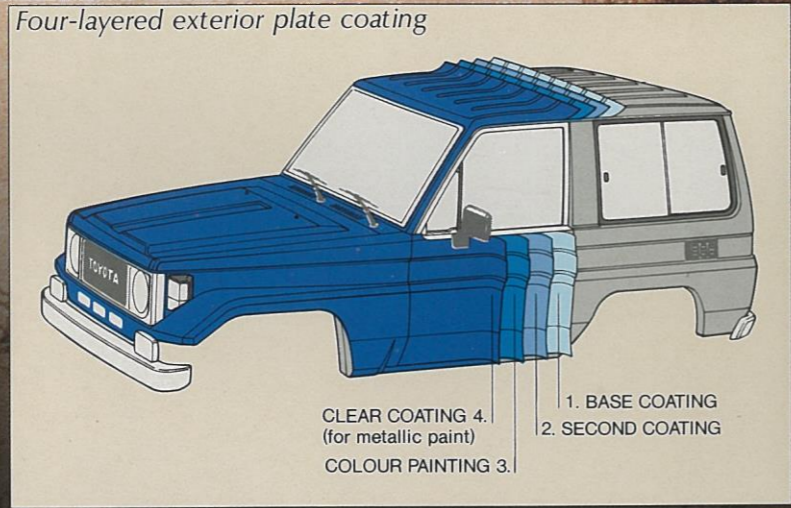
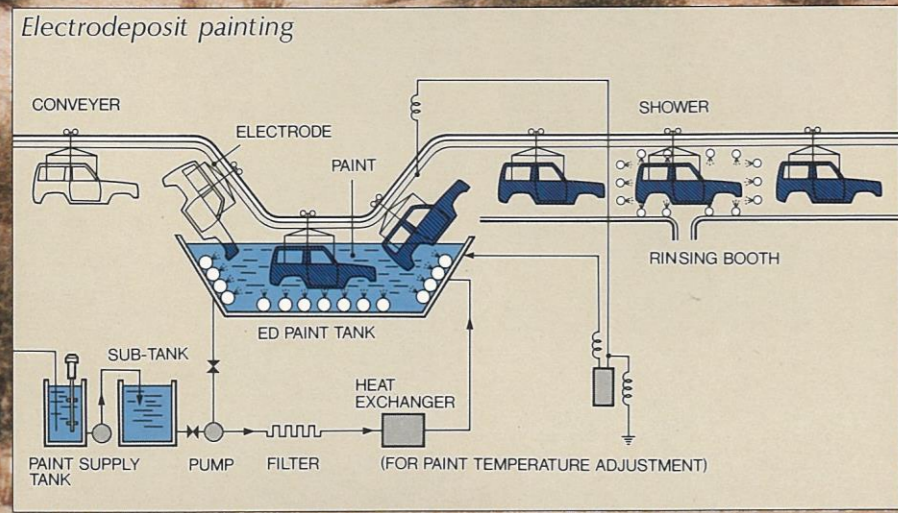
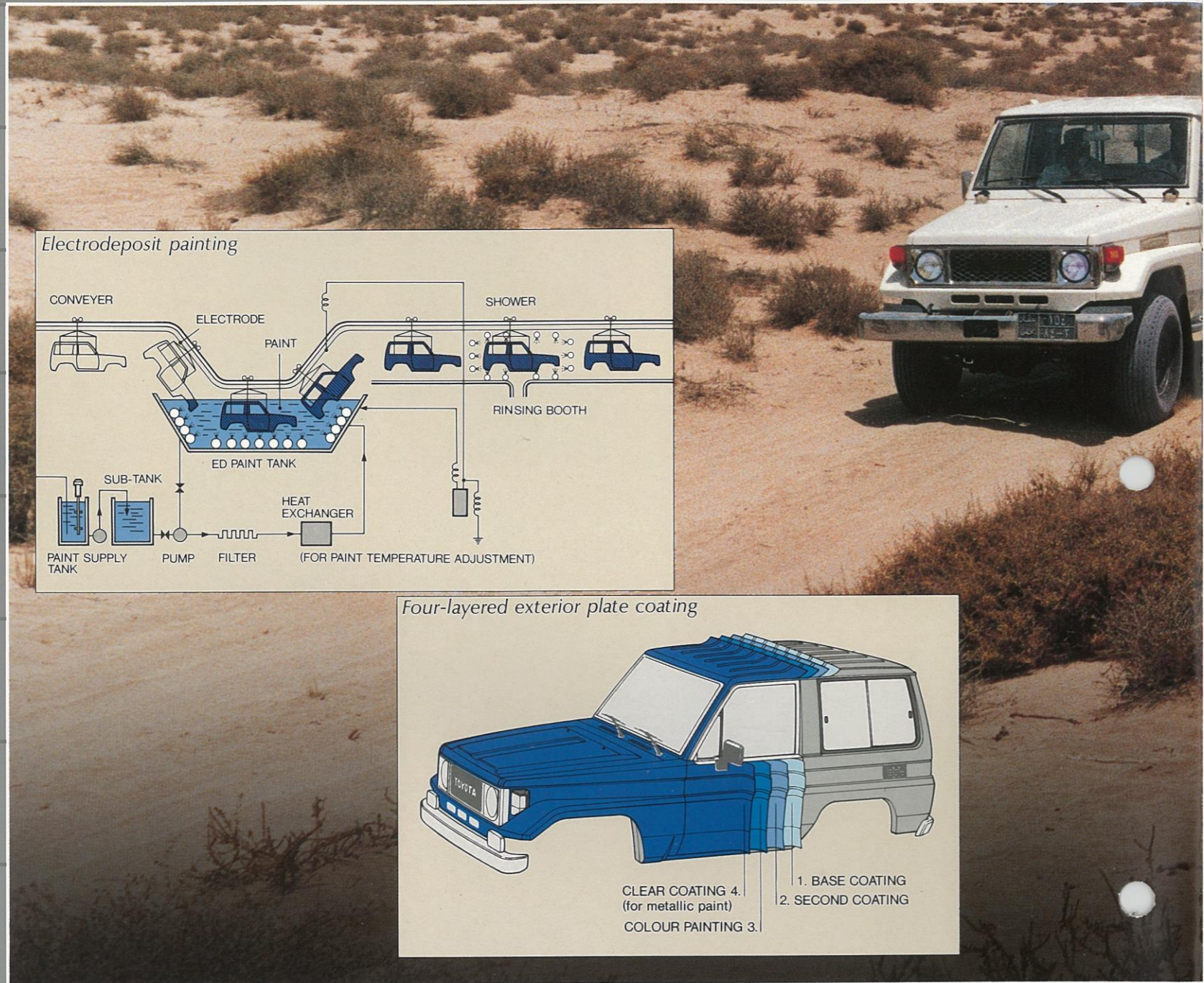

Toyota Quality—the secret of Land Cruiser’s famous durability. Every Toyota Land Cruiser undergoes extraordinary measures to protect it from the damaging effects of rust and corrosion. Galvanealed steel and newly-developed rust-resistant metals are used extensively. Body parts are shaped to prevent moisture from collecting inside. Bodies are dipped in electrodeposit anti-corrosion baths and get a thorough undercoating. Then, prototypes are tested for resistance to water and salt. But the most important test Land Cruiser has ever passed is the test of time. Satisfied owners have put Toyota to that test and come out winners. All over the world.



Land Cruiser set the standards in four-wheel-drive toughness. And today’s Land Cruisers live up to that same high standard. The body and frame are built rugged and rigid. Frame plates are thick. And the whole is welded, not riveted, for frame strength. The new closed-section frame-building technique gives the new Land Cruisers a strong, rugged frame you can count on. Famous Land Cruiser toughness has gone a step further.

Pickup, Long Wheelbase

SPECIFICATIONS	LAND CRUISER					
	Hard Top	Soft Top	FRP Top	Soft Top	Hard Top	Pickup
	Short Wheelbase		Middle Wheelbase		Long Wheelbase	

DIMENSIONS & WEIGHTS							
Overall length	mm.	4060		4350		4995	4885
Overall width	mm.	1690					
Overall height	mm.	1900	1910		1955	2080	1935/1940*3
Wheelbase	mm.	2310		2600	2980		
Tread	Front	mm. 1415					
	Rear	mm. 1410					
Ground clearance	mm.	205			230		
Deck inside	Length*1	mm. 1065/875*5		1165	1355/1165*5	2085/1870*5	2155
	Width	mm. 1510/1170*6		1470	1580/1170*6	1510/1170*6	1600/1665*9
	Height	mm. 1110		1130	1160	1130	1265
Kerb weight*2 (4-speed manual)	kg.	1660/1665*4/1710*7	1705/1710*4	1630/1635*4/1680*7	1675	1755*4	1715/1720*4
Gross vehicle weight	kg.	2380		2410		3035	

ENGINE											
Type	6-cyl. in-line OHV	4-cyl. in-line OHV	6-cyl. in-line OHV	4-cyl. in-line OHV	6-cyl. in-line OHV	4-cyl. in-line OHV	6-cyl. in-line OHV	4-cyl. in-line OHV	6-cyl. in-line OHV	4-cyl. in-line OHV	
	Gasoline	Diesel	Gasoline	Diesel	Gasoline	Diesel	Gasoline	Diesel	Gasoline	Diesel	
Piston displacement	cc.	3955	3431	3955	3431	3955	3980	3431	3955	3980	
Bore and stroke	mm.	94 x 95	102 x 105	94 x 95	102 x 105	94 x 95	91 x 102	102 x 105	94 x 95	91 x 102	
Compression ratio	to 1	8.1	20.0	8.1	20.0	8.1	20.7	20.0	8.1	20.7	
Max. horsepower (SAE net)	kW/rpm	101-108*7/4200	69/3500	101-108*7/4200	69/3500	101/4200	79/3500	69/3500	101/4200	79/3500	
Max. torque (SAE net)	Nm/rpm	275/2200	221/2100	275/2200	221/2100	275/2200	246/1800	221/2100	275/2200	246/1800	
Fuel system		Down-draft, 2-barrel, single carburettor (Gasoline engines); Distribution type fuel injection pump (2.4-litre Diesel engine); In-line type fuel injection (Other Diesel engines)									
Fuel tank capacity	litres	90				90/180*11					

CHASSIS		LAND CRUISER II				LAND CRUISER STATION WAGON			
Clutch		Single dry plate with diaphragm springs (Manual transmission)							
Suspension	Front	Semi-elliptic leaf springs							
	Rear	Semi-elliptic leaf springs							
Brakes	Front/Rear	Drum with tandem master cylinders and booster							
Transmission	4-speed manual	1st: 4.843; 2nd: 2.618; 3rd: 1.516; 4th: 1.000; Rev.: 4.843 1st: 3.928; 2nd: 2.333; 3rd: 1.451; 4th: 1.000; Rev.: 4.743 (Land Cruiser II)							
	5-speed manual	1st: 4.843; 2nd: 2.618; 3rd: 1.516; 4th: 1.000; 5th: 0.845; Rev.: 4.843 1st: 3.928; 2nd: 2.333; 3rd: 1.451; 4th: 1.000; 5th: 0.851; Rev.: 4.743 (Land Cruiser II)							
	4-speed automatic	1st: 2.950; 2nd: 1.530; 3rd: 1.000; 4th: 0.717; Rev.: 2.678							
Transfer shift		2-speed, helical gear ratio; Low: 1.960, High: 1.000 / Low: 2.276, High: 1.000 (Land Cruiser II)							
Final reduction gear ratio	to 1	4.111/3.700 (4.0-litre gasoline models with manual transmission)							
Steering		Ball nut							
Min. turning radius (Tyres)	m.	5.3/5.7 (4WD)		5.8/6.2 (4WD)		6.5/6.9 (4WD)			
Tyres	Front/Rear	7.00-15-6PRLT		7.50-16-8PRLT		7.50-16-8PRLT		7.50-16-6PRLT	

*1: Rear seats folded
 *2: Without rear seats models
 *3: Heavy duty spec.
 *4: 5-speed manual transmission models
 *5: With transverse rear seats models
 *6: With facing rear seats models
 *7: 4-speed automatic transmission models
 *8: With vinyl cover models
 *9: With vinyl cover and facing rear seats models
 *10: With transverse third seat
 *11: With optional 90-litre sub fuel tank

LAND CRUISER II		LAND CRUISER STATION WAGON			
Hard Top	Soft Top	Wagon		Wagon G	Wagon G/GX*10
Short Wheelbase		Standard Roof	High Roof	Standard Roof	High Roof

	4060	4675			
	1800				
1930/1935*3	1935/1940*3	1905	1920	1915	1805
	2310	2730			
	1475				
	1460				
	225	205		215	230
	1065/875*5		1765		1770
1260*9	1510/1170*6		1580/1170*6		1520
	1110		1130		1045
			1145		1025
1865/1870*4	1820	1475	1550/1555*4	1445/1450*4	1520
	2110		2760		2910
			2760		2910

Type	4-cyl. in-line OHV	4-cyl. in-line OHC	6-cyl. in-line OHV	4-cyl. in-line OHV	6-cyl. in-line OHV	4-cyl. in-line OHV	6-cyl. in-line OHV	4-cyl. in-line OHV	6-cyl. in-line OHV	4-cyl. in-line OHV
	Diesel	Gasoline	Diesel	Gasoline	Diesel	Gasoline	Diesel	Gasoline	Diesel	Gasoline
Piston displacement	cc.	3980	3431	2366	2446	2366	2446	3955	3980	3431
Bore and stroke	mm.	91 x 102	102 x 105	92 x 89	92 x 92	92 x 89	92 x 92	94 x 95	91 x 102	102 x 105
Compression ratio	to 1	20.7	20.0	9.0	22.3	9.0	22.3	8.1	20.7	20.0
Max. horsepower (SAE net)	kW/rpm	79/3500	69/3500	77/4800	55/4000	77/4800	55/4000	101/4200	79/3500	69/3500
Max. torque (SAE net)	Nm/rpm	246/1800	221/2100	184/3200	158/2200	184/3200	158/2200	275/2200	246/1800	221/2100
Fuel system		fuel injection (Other Diesel engines)								
Fuel tank capacity	litres	90								

	4.300/4.875 (Diesel models)		4.111/3.700 (4.0-litre gasoline models with manual transmission and 4.0-litre diesel models)			
	5.3/5.7 (4WD)		6.2/6.7 (4WD)			
	7.00-15-6PRLT		7.00-15-6PRLT		7.00-16-6PRLT	
					7.50-16-6PRLT	

● Toyota Motor Corporation reserves the right to alter any details of specifications and equipment without notice. Details of specifications and equipment are also subject to change to suit local conditions and requirements. Please inquire at your local dealer for details of any such changes that might be required for your area.
 ● Note: Vehicles pictured in this catalogue may vary from models available in your area.
 Vehicle body colour might differ slightly from the printed photos in this catalogue.